

ULTRALOC

Bolt

Installation and User Guide

(V1.2)

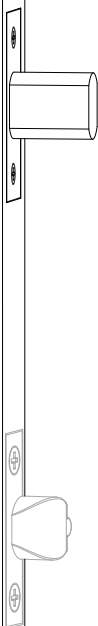
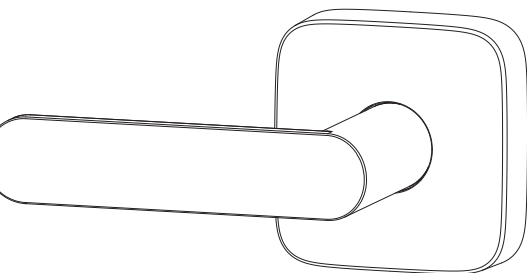

Important Notes

Test before final installation: Always install and test the lock with the door open to avoid accidental lockouts.

Read carefully: Review all instructions thoroughly before contacting Customer Support.

Before returning the lock: Remove the device from the app settings, then contact Customer Support.

Operating temperature:

Exterior: -4 °F (-20 °C) to 149 °F (65 °C)

Interior: 14 °F (-10 °C) to 131 °F (55 °C)

Do not use a power drill for installation.

Do not insert batteries until the lock is fully installed.

Use AA alkaline batteries only. Rechargeable or non-alkaline batteries are not recommended.

Note: The Exterior Assembly of Bolt is waterproof, but the Interior Assembly is not waterproof due to the exposed battery compartment.

Product Registration

For the best service and warranty coverage, please register your product at: www.ultralq.com/register

Terms & Policies

Before using any ULTRALOQ products, please read all applicable terms, rules, policies, and usage provisions at:

www.ultralq.com/privacy

By using your ULTRALOQ device, you agree to the Privacy Policy.

Need Help?

For technical documents and more

Please visit support.ultralq.com

or call **1-844-439-8832**

Packing List

Interior
Assembly

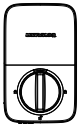

Exterior
Assembly



Interior Assembly
Mounting Plate



Dust Box



Strike Plate



Bolt

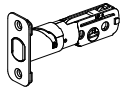

Screw A

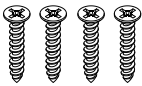

Screw B

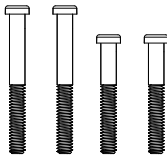

Screw C



Backup Key



Reset Needle



Drill Template

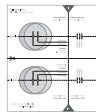

User Guide



Quick Setup
Guide

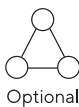

Installation Guide

Installation Video



Scan the QR code to watch the installation video.

Or you can also view the website directly.
www.ultraloq.com/bolt/guide

1. Preparing Door

Before installation, check that your door meets the required dimensions:

Step 1:

Confirm that the door thickness is 1-3/8" to 2-1/4" (35 mm-57 mm).

Step 2:

Confirm that the main bore hole diameter is 2-1/8" (53 mm).

Step 3:

Confirm that the backset is either 2-3/8" (60 mm) or 2-3/4" (70 mm).

Step 4:

Confirm that the edge hole diameter is 1" (25 mm).

Step 5:

Confirm that the latch hole depth in the frame is at least 1" (25 mm).

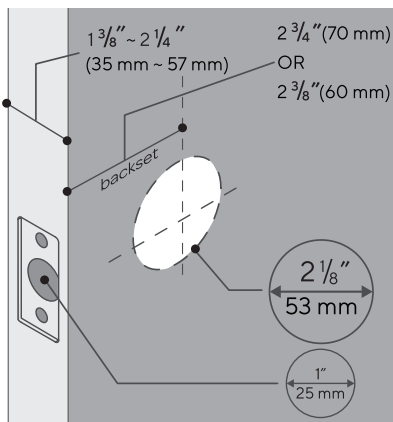
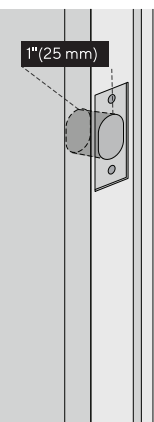

If installing on a new door, use the provided Drill Template to drill holes to the correct size.

2. Installing the Bolt and Strike

Step 1: Install the Bolt

Insert the bolt into the door with the "UP ↑" icon facing upward.

Note : By default, the bolt is set to a 2-3/8" (60 mm) backset.

To adjust to 2-3/4" (70 mm):

1. Ensure the bolt is fully retracted.
2. Press the bolt, then twist it until you hear/feel a slight click.
3. This locks it in the extended backset position.

Important: Always retract the bolt before making adjustments.

Step 2: Install the Strike

- Place the strike plate on the door frame.
- Ensure the latch can extend fully into the strike hole.
- Secure the strike plate with the provided screws A(x4).

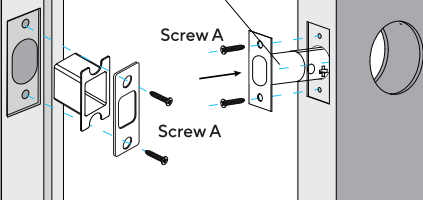
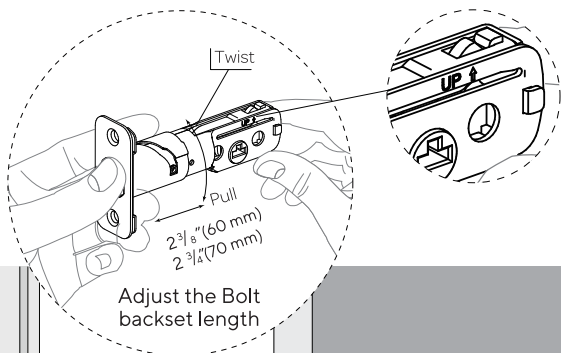

3. Installing the Exterior Assembly

Step 1: Position and Install

Ensure the bolt is fully retracted.

Make sure the cylinder tailpiece is horizontal, with the bump pointing upward.

Carefully install the Exterior Assembly onto the door.

Do not insert the mechanical key during installation.

Step 2

The direction of the cylinder tailpiece is consistent with the bolt. The cable goes through the hole **below** Bolt.

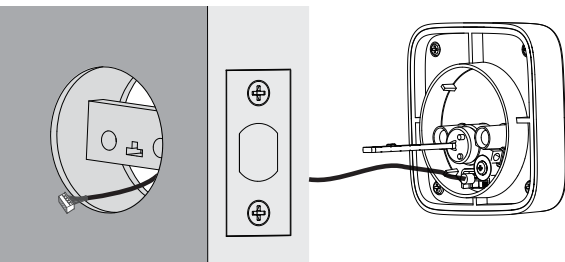

4. Installing the Interior Assembly Mounting Plate

Step 1: Route the cable

Route the cable through the hole in the Interior Assembly Mounting Plate.

Step 2: Secure the Mounting Plate

Secure the Interior Assembly Mounting Plate to the Exterior Assembly using Screw B(x2).

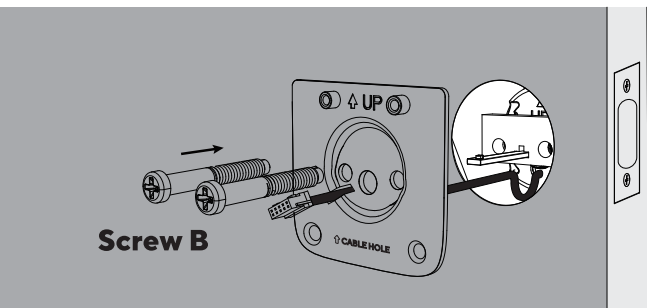

Warning: Longer screws for 1-3/4"~ 2-1/4" (45mm~57mm) thickness door, Shorter screws for 1-3/8"~ 1-3/4" (35mm~45mm) thickness door.

5. Installing the Interior Assembly

Warning: Do not install the batteries before attaching the Interior Assembly. Doing so may prevent the keypad from powering on correctly.

Step 1: Remove Battery Cover

Remove the battery cover from the Interior Assembly.

Step 2: Connect the Cable

Insert the cable connector into the socket on the Interior Assembly.

Make sure the concave and convex sides are aligned.

Press firmly until the connector is fully seated.

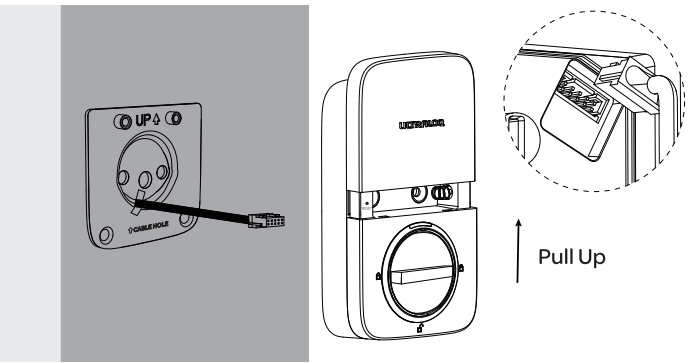

Step 3: Set to Unlocked Position

Rotate the knob to the vertical position to keep the lock unlocked during installation.

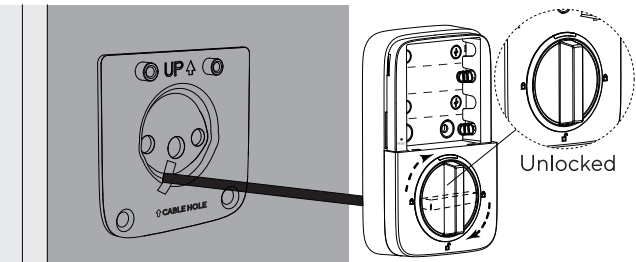

Step 4: Attach the Interior Assembly

Place the Interior Assembly onto the Mounting Plate.

- Secure it with Screw C (x2).

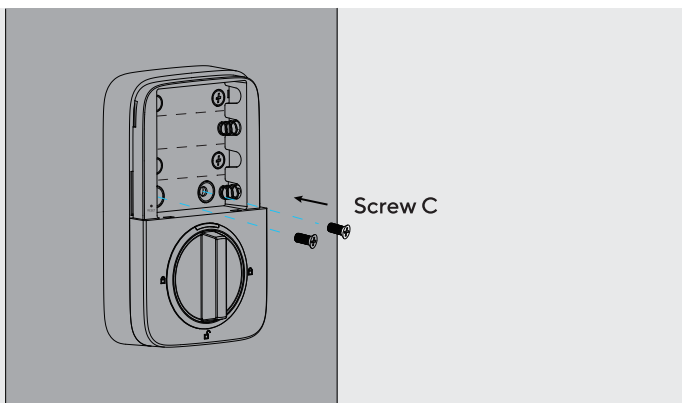

6. Installing the Batteries & Door Handling Process

This step allows the lock to automatically detect which way your door opens.

Step 1

Rotate the knob to the vertical position to keep the lock unlocked.

Step 2

Insert 4 AA alkaline batteries and replace the battery cover.

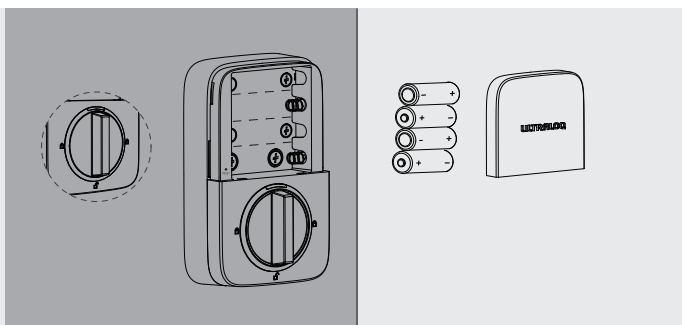

Step 3: Perform Direction Calibration

- Keep the bolt in the unlocked position.
- Press and hold the “5” key on the keypad for 3 seconds.
- The lock will automatically run the door-handling process, confirming the correct orientation.

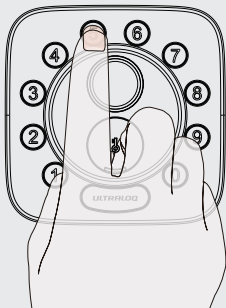

Note: To prevent deadbolt jamming, ensure this step is performed after the lock is installed on the door.

User Guide

User Guide Video

Please scan the QR code on the left to watch the user guide video. You can also visit the website directly at <https://support.ultralq.com/hc/en-us/articles/49607301033241-Installation-and-Setup-Guide-for-ULTRALOQ-Bolt>



For the configuration guide for integrations (Alexa, Google Assistant, IFTTT, Apple Home, and SmartThings), please scan the QR code on the right or visit support.ultralq.com, then choose “Works with” to watch the user guide video.

1. Product Overview

1.1 Exterior Components

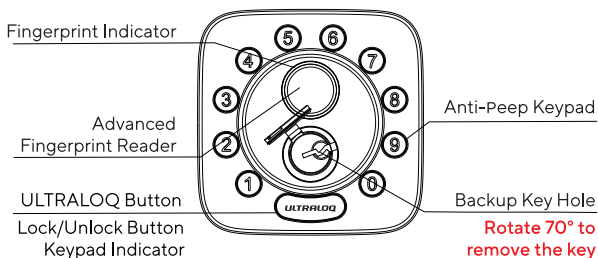

Advanced Fingerprint Reader

Authenticates your fingerprint to unlock the door from outside.

Fingerprint Indicator

Indicator:

1. Green: Access granted or setup successful
2. Red: Access failed

ULTRALOQ Button(Lock/Unlock Button)

Functions:

1. Manually lock/unlock the door
2. Illuminate the keypad
3. Confirm actions during setup

Indicator Lights:

1. Green: Operation successful
2. Blue: Connecting or processing
3. Red: Operation failed
4. Blinking Red: Low battery warning

Backup Key Hole With Rubber Cover

Provides mechanical key access in case of battery failure or emergencies.

Anti-Peep Keypad

Lets you enter random digits before or after the correct code to prevent others from guessing your PIN.

ULTRALOQ Button has the following functions:

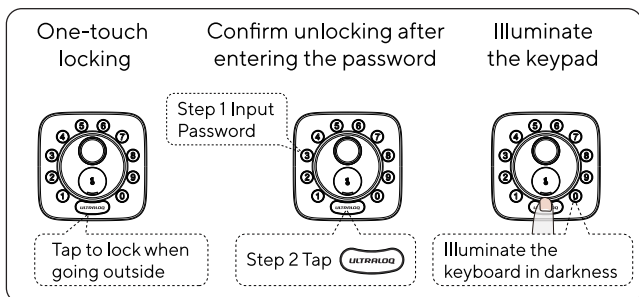

1.2 Interior Components

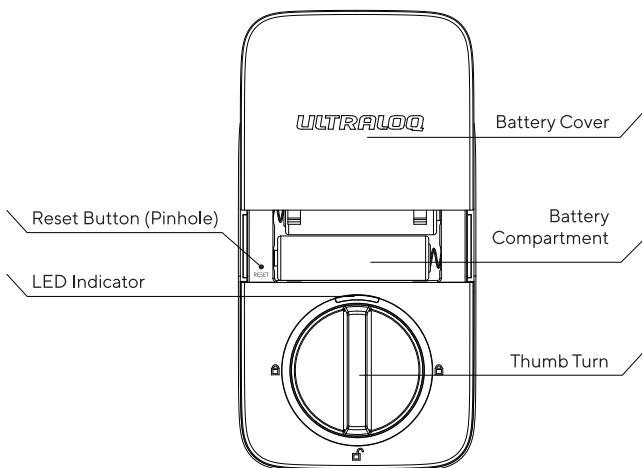

Reset Button (Pinhole)

Used to reset the lock to Factory Default settings.

To reset, use a Reset Needle to press and hold the reset button (located under the battery cover) for about 10 seconds until you hear one long beep followed by two short beeps.

Note: If the lock was paired with an app, please first tap "Remove Device" in the app before resetting. For detailed reset instructions, refer to Page 13.

Battery Compartment

Holds 4 AA alkaline Batteries.

Note: Insert 4 AA alkaline Batteries or UTEC Lithium Batteries. Rechargeable or other battery types are not recommended.

Battery Cover

Protects the battery compartment and includes labels for the Program Code and (optionally) the Matter setup QR code.

Thumb Turn

Used to manually lock and unlock the door from inside.

LED Indicator

Turns green when the door is unlocked.

1.3 Low Battery Alarm

When the battery is low, the lock will beep three times, and the The ULTRALQO button will flash red.

Note: Please replace the batteries promptly to avoid lock failure.

2. Lock Setup



Scan QR code to download the App



Step 1: Download App

Scan the QR code to download the app, or search for:

“U home ” in the App Store (iOS) .

“U home ” in the Google Play Store (Android).

Step 2: Register and Log In

Open the app.

Create an account or log in with your existing credentials.

Step 3: Prepare the lock

- Ensure the lock is in Factory Default Mode.
- Press and hold the reset pin for 10 seconds until you hear 1 long beep + 2 short beeps.
- Turn on Bluetooth on your smartphone.
- Stay within 10 feet (3 m) of the lock during setup.

Step 4: Choose the setup mode

Select one of the following modes:

Matter Mode:

Add the device to your Matter-compatible hub via Matter over Thread.

To enable: Press the reset pin into the reset hole for 1 second until you hear a short beep.

Matter setup remains active for 10 minutes.

Bluetooth Mode:

Add the device to the Xthings Home app via Bluetooth.

Bluetooth remains active for 30 seconds.

Enable Bluetooth Setup Mode: Press any button on the lock pad to wake up the Bluetooth, the Bluetooth setup will remain active for 30 seconds.

Wi-Fi Mode:

In the Xthings Home app, switch the lock to Wi-Fi mode. Once enabled, you can control the lock remotely.

Note: Wi-Fi and Matter cannot run simultaneously.

Pairing Instructions

- 1 Follow the on-screen steps in the Xthings Home app.
- 2 Ensure your phone is connected to a 2.4 GHz Wi-Fi network. (5 GHz not supported.)
- 3 Search for the lock within 30 seconds. If setup doesn't start, press any key to reactivate Bluetooth.

Don't want to use the app?

You can program the lock manually in Standalone Mode. See the guide on Page 15 for instructions.

3. Using Your Lock

3.1 Unlocking from Outside

Unlock using any of these methods:

- **User Code**

Enter your 4–8 digit code, then press ULTRALOCK button.

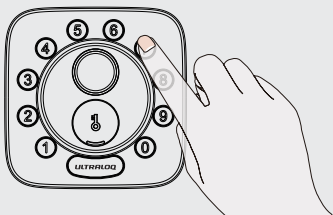

- **Fingerprint**

Place your registered finger on the reader.

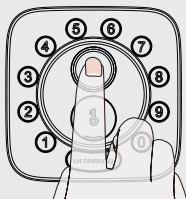

• App Control

Unlock via Xthings Home app (Bluetooth or Wi-Fi).

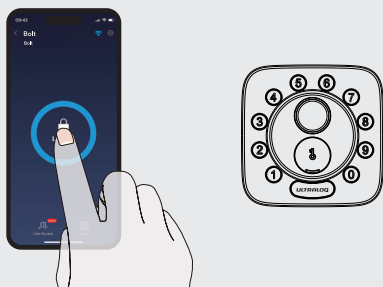

• Mechanical Key

Insert and turn the backup key.

• Voice Assistant / Smart Home

If integrated, unlock via supported assistants.

3.2 Locking from Outside

- Press the ULTRALOCK button to lock instantly.
- Enable Auto Lock in the app to lock automatically after closing the door.

3.3 Unlocking from Inside

Rotate the interior thumb turn to the vertical position to unlock.

3.4 Resetting the Lock

Resetting will erase all data and restore factory default settings

If you are the Xthings Home app owner:

1. Open the app and click "Remove Device" to remove the lock from your Xthings Home app.
2. You will hear 1 long beep followed by 2 short beeps, confirming the reset was successful.

If the lock does not reset automatically:

1. Use a Reset Needle to press the Reset Button under the battery cover.
2. Hold for 10 seconds, until you hear 1 long beep followed by 2 short beeps.

3.5 Replacing the Batteries

Use **4 high-quality AA alkaline batteries** when power is low or depleted. Open the battery cover and replace all batteries at once for optimal performance.

Important Note:

Keep at least one Backup Key in a secure location outside your home in case of battery failure.

3.6 Enable Or Disable Auto Lock

You can enable or disable the Auto Lock feature directly from the keypad:

To Enable Auto Lock:

Ensure the bolt is in the unlocked position.

Press and hold the "1" button for 3 seconds.

The Indicator will light up green and you'll hear two beeps.

To Disable Auto Lock:

Ensure the bolt is in the unlocked position.

Press and hold the "0" button for 3 seconds.

The Checkmark Indicator will light up green and you'll hear two beeps.

Tip: You can also enable/disable Auto Lock and customize the relock delay in the Xthings Home app.

3.7 Anti-Peep Keypad

The lock supports a Vague Code (anti-peep feature) of up to 16-digits. As long as your correct user code appears in the correct sequence within the digits entered, the door will unlock.

Example
User Code: 123456

Valid Vague Code

123456XXXXXX

XXXXXXXX123456

XXX123456XXX

"X" represents any random digit. The correct code must appear in order, even if surrounded by other digits.

3.8 Fingerprint Placement Tips

Bottom View



Top View

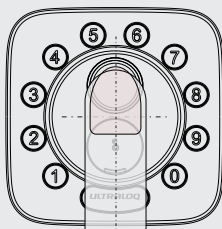

Side View

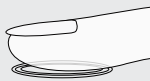

- For higher recognition accuracy, place your finger flat and fully cover the Fingerprint Reader, making contact with the surrounding metal ring.
- Ensure both your finger and the reader are clean and dry. Use a clean, lint-free cloth to wipe the reader if needed.
- When enrolling, scan your fingerprint from multiple angles for better recognition.
- Do not tap too quickly or move your finger during scanning — hold steady for the best results.

4. Standalone Mode Programming Guide

Note: It is recommended to use the Xthings Home app for setup.









If you don't have a smartphone or prefer not to use the app, follow the instructions below.

Warning: Standalone Mode is not available once the lock is registered in the app.

To enable Standalone Mode, you must reset the lock to Factory Default Mode first.









4.1 Add Admin Code in Standalone Mode

To add the Admin Code, you need the Program Code found on the battery cover.





Operation	LED & Sound Indicator
Hold  for 3 sec	2 beeps with  light on
Enter 6 digit Program Code and press 	2 beeps with  light on
Enter a 4-8 digit Admin Code and press 	2 beeps with  light on
Re-enter the Admin Code and press 	2 beeps with  light on

Success	All lights off
---------	----------------

4.2 Add User Code in Standalone Mode

Operation	LED & Sound Indicator
Hold  for 3 sec	2 beeps with  light on
↓	
Enter your Admin Code and press 	2 beeps with  light on
↓	
Enter a 4-8 digit User Code and press 	2 beeps with  light on
↓	
Re-enter the User Code and press 	2 beeps with  light on
↓	
Success	All lights off

4.3 Add Fingerprint in Standalone Mode

Operation	LED & Sound Indicator
Hold  for 3 sec	2 beeps with  light on
↓	
Enter your Admin Code and press 	2 beeps with  light on
↓	
Press Fingerprint 6 times	5 beeps and digit buttons blink 5 times
↓	
Success	All lights off

4.4 Delete the Admin Code and all User Codes

To delete the Admin and all Users Codes, reset the lock to Factory Default Mode.

4.5 How to Reset in Standalone Mode?

Use a Reset Needle to press the Reset Button (located under the battery cover).

Hold for 10 seconds, until you hear 1 long beep followed by 2 short beeps.

The lock is now reset and ready to be programmed again in Standalone Mode.

FAQ

1. How do I reset Bolt?

Resetting will erase all data and restore factory default settings.

If registered in the Xthings Home app: Tap "Remove Device" in the app. The lock will automatically reset.

If in Standalone Mode: Use a Reset Needle to press the Reset Button (under the battery cover) for 10 seconds, until you hear 1 long beep followed by 2 short beeps.

2. What if I lost the smartphone paired with the lock?

Visit www.ultraoq.com/account.html

Or login to the Xthings Home app on another smartphone or tablet.

Change your Xthings Home Account password to secure your device.

3. How can I unlock the lock if the battery dies?

When the battery is low, the lock will emit three beeps and the low battery indicator will light up.

Replace the batteries as soon as possible.

If the battery is fully drained, use the backup key to unlock the door.

Please keep at least one backup key in secure location outside your home.

4. What's the difference between Owner, Admin, Normal User and Temporary User?

Role	Permissions
Owner	Original registrant. Full access to settings, logs, and user management.
Admin	Can unlock via app, code, or keycard. Can manage users and settings.
Normal User	Can unlock via app, code, or keycard. No admin privileges.
Temporary User	Limited access during a scheduled time window.

5. Can I use third-party accessories (e.g., bolt)?

It is recommended to use the original ULTRALOQ accessories for best performance and stability.

6. What is the user capacity and the log capacity?

The lock can store up to 50 users, and each user can register 1 code and 2 fingerprints. It can also store up to 1,000 activity logs. Once it's full, the newest entries will automatically overwrite the oldest.

7. How can I extend battery life?

Disable Remote Access to Lock in the Xthings Home app to significantly extend battery life.

Note: Disabling this will turn off remote features including Alexa, Google Assistant, IFTTT, Apple Home, SmartThings and smart notifications.

8. Do I need an ULTRALOQ Bridge?

No, the lock has built-in Wi-Fi and does not require an external hub.

9. What network does the lock support?

The lock supports 2.4 GHz Wi-Fi only.

*5 GHz Wi-Fi is not supported.

10. What is the Program Code?

The Program Code is a unique 6-digit code found on the battery cover. It is required to unlock the lock in Factory Default Mode and to initialize programming in Standalone Mode.

11. How do I switch between Wi-Fi and Matter Mode?

Wi-Fi Mode: Add the device to your router via the Xthings Home app for remote control.

Matter Mode: Add the device to a Matter-compatible hub via Matter over Thread for smart home integration.

Note: Wi-Fi and Matter modes cannot run simultaneously.

You may switch between them in the Xthings Home app.

Default factory setting: Matter Mode.

ULTRALOQ

A Brand of Xthings

© 2026 Xthings Inc. All rights reserved.

ULTRALOQ and ULTRALOQ logo are trademarks of Xthings Inc. or its affiliates registered in the U.S. and other countries and regions. All other trademarks are the property of their respective owners.

Xthings Inc. 47703 Fremont Boulevard, Fremont, CA 94538

Engineered by Xthings, assembled in China.